



KEHDCB-2000

**ELECTRO HYDRAULIC  
THRUSTER OPERATED  
DISC BRAKE**



KEHDCB-7000

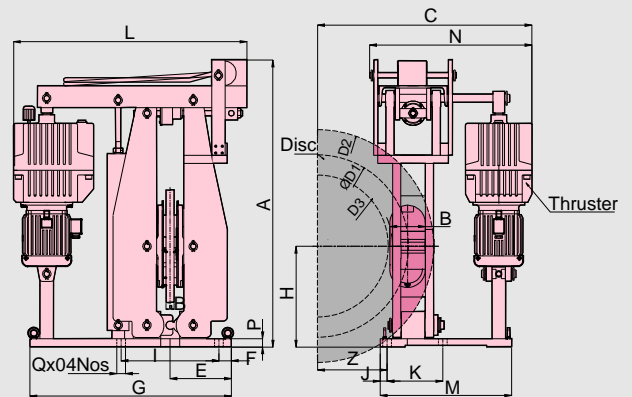
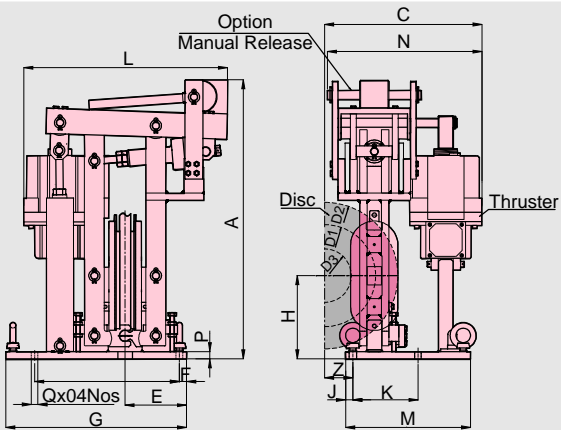

TECHNICAL DATA

MODEL: KEHDCB

CATALOG No: 8416.05.077.000

Model	A Max	B Shoe Width	D Liner Width	E	F	G	H	I	J	K	L	M	N	P	Q
KEHDCB-2000	830	130	110	170	20	500	230	400	20	180	625	345	450	20	18
KEHDCB-7000	1055	130	110	225	45	740	370	360	25	205	858	483	596	30	32

Model: KEHDCB-2000 Weight: 250kg (without thruster) BRAKE DISC =30MM THK					TORQUE IN NM Thruster Type					
D2	D1	D3	Z	C MAX	EHT 30/5		EHT 50/6		EHT 80/6	
					Min	Max	Min	Max	Min	Max
400	270	120	140	665	600	830	710	1760	1190	2610
450	320	150	165	690	680	950	820	2020	1350	3000
500	370	200	190	715	750	1070	920	2260	1500	3360
560	430	260	220	745	850	1210	1040	2560	1700	3810
630	500	330	255	780	980	1380	1180	2920	1950	4350
710	580	410	295	820	1100	1590	1370	3380	2250	5020

**Note:**

D1: Theoretical friction diameter  
D2: Outer disc diameter  
D3: Max possible coupling or hub Diameter

**Standard feature:**

1. Powder coated in red color.
2. Manual release option.
3. Torque adjustment option.

Model: KEHDCB-7000 Weight: 315kg (without thruster) BRAKE DISC =30MM THK					TORQUE IN NM Thruster Type					
D2	D1	D3	Z	C MAX	EHT 121/6		EHT 201/6		EHT 301/6	
					Min	Max	Min	Max	Min	Max
560	430	260	140	672	2650	6000	3200	9200	2700	12400
630	500	330	175	707	3200	7250	3850	11100	3250	14950
710	580	410	215	747	3700	8350	4450	12800	3750	17200
800	670	500	260	792	4250	9600	5100	14700	4300	19750
900	770	600	310	842	4750	10800	5750	16550	4850	22250
1000	870	700	360	892	5350	12200	6500	18650	5450	25100
1250	1120	950	485	1017	6800	15500	8250	23700	6900	31850

**Optional feature:**

1. Sintered Brake pad.
2. Autowear adjustment.
3. Brake ON/OFF switch.
4. Pins and Fasteners are SS material
5. Thruster-IP-65/ Flame proof Thruster

# Our Other Products



Dual Motor Hydraulic Power Pack With PLC Based Electrical Control Panel



EHT Drum Brake

EHT Disc Brake

DC EM Drum Brake

Hydraulic Disc Brakes

Pneumatic Brakes

Pneumatic Brakes

K-DAF Dual Spring Hydraulic Disc Brake

Hydraulic Brake Mono Spring

Heavy Duty Thruster

Rail Clamp

Friction Liners (sintered / Organic)

Organic Liner

Friction Disc



An ISO 9001 - 2008 Certified Company



**KATEEL ENGINEERING INDUSTRY (P) LTD.**

# 223, 80 feet Outer Ring Road, Nagarabhavi, 6th Block, 2nd Stage  
 BANGALORE - 560 072. INDIA. Phone : +91-80-23484179 / +91-80-23210850  
 Fax : +91-80-23481305 E-mail : info@kateel.com / mktg@kateel.com

Web : <http://www.kateel.com>