

DC ELECTROMAGNETIC DRUM BRAKE

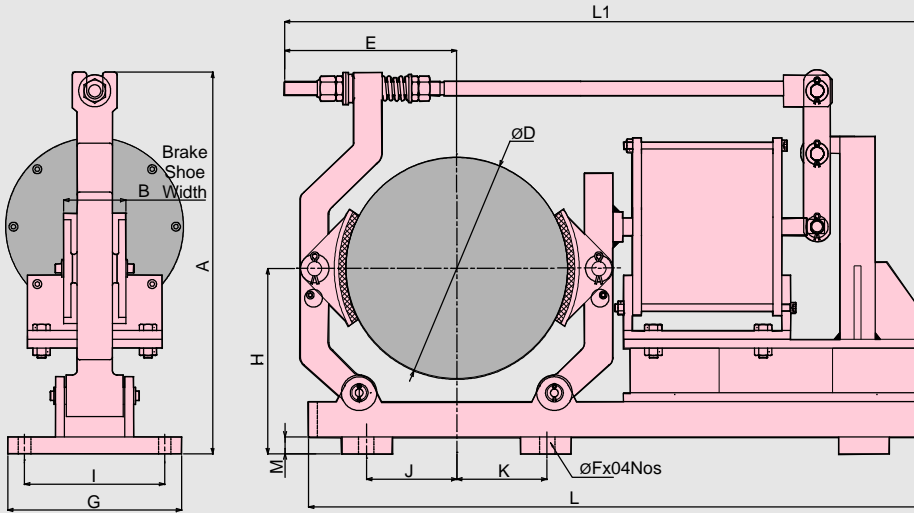

TECHNICAL DATA

MODEL: K-EMDB

CATALOG No: 8409.02.001

Size	METRIC (Dimension in mm)								AISE Inch (Dimensions)							
	100	150	200	250	300	400	500	600	4"	6"	8"	10"	13"	16"	19"	23"
A	280	280	338	400	480	590	716	845	11	11	13-5/8	15-3/4	19	22-3/4	25-5/8	30-3/8
B	80	80	80	89	140	165	216	279	3-1/8	3-1/8	3-1/8	3-1/2	5-1/2	6-1/2	8-1/2	11
D	100	150	200	250	300	400	500	600	4	6	8	10	13	16	19	23
E	135	135	164	200	238	305	360	418	5	5	6-1/2	8	9-7/8	12-1/4	14-1/2	18-1/8
F	17	17	17.5	17.5	22	25	25	38	11/16	11/16	11/16	11/16	13/16	1-1/16	1-1/16	1-5/16
G	185	185	121	196	165	184	400	484	7-1/4	7-1/4	7-1/4	7-3/4	11	13	15-3/4	19
H	137	137	170	212	250	320	400	475	5-1/2	5-1/2	7	8-3/8	9-7/8	12-1/8	13-1/4	15-7/8
I	145	145	60	158	80	90	100	126	5-3/4	5-3/4	5-3/4	6-1/4	9	10-3/4	13	16
J	90	90	175	101.5	250	170	205	250	3-1/2	3-1/2	3-1/4	4	5-7/5	7-1/2	9-1/4	11-7/5
K	90	90	175	101.5	250	170	205	250	3-1/2	3-1/2	3-1/4	4	5-7/5	7-1/2	9-1/2	11-7/5
L	500	500	600	552	789	733	932	1092	19-1/4	19-1/4	19-1/4	21-6/8	26-1/2	29-2/8	29-2/8	41-3/4
L1	530	530	581	631	762	861	1043	1201	20-8/7	20-8/7	21-8/7	25	29-1/4	33	40-8/7	48-4/8
M	12	12	12	15	18	20	20	22	2/4	2/4	13/16	3/4	3/4	1-5/16	1-5/16	1-5/16

TORQUE RATING FOR SHUNT BRAKES

BRAKE SIZE	TORQUE RATING					
	DC Operation				AC Operation	
	Cont. Duty		Int. Duty		Cont. Duty	
	MM	Lbf.ft	Nm	Lbf.ft	Nm	Lbf.ft
100	18.4	25	29.5	40	29.5	40
150	51.6	70	70.8	96	70.8	96
200	75	102	100	136	100	136
250	150	203	200	271	200	271
300	400	543	550	746	550	746
400	750	1017	1000	1356	1000	1356
500	1500	2034	2000	2712	2000	2712
600	3000	4067	4000	5423	4000	5423

Our Other Products



Dual Motor Hydraulic Power Pack With PLC Based Electrical Control Panel



An ISO 9001 - 2008 Certified Company



Kateel®

KATEEL ENGINEERING INDUSTRY (P) LTD.

223, 80 feet Outer Ring Road, Nagarabhavi, 6th Block, 2nd Stage
 BANGALORE - 560 072. INDIA. Phone : +91-80-23484179 / +91-80-23210850
 Fax : +91-80-23481305 E-mail : info@kateel.com / mktg@kateel.com

Web : <http://www.kateel.com>