

HYDRAULIC FAIL SAFE DISC BRAKE

MODEL:

Data Sheet No.

Spring Applied - Hydraulically Released

K-DA/F70-MS

DS042011.28

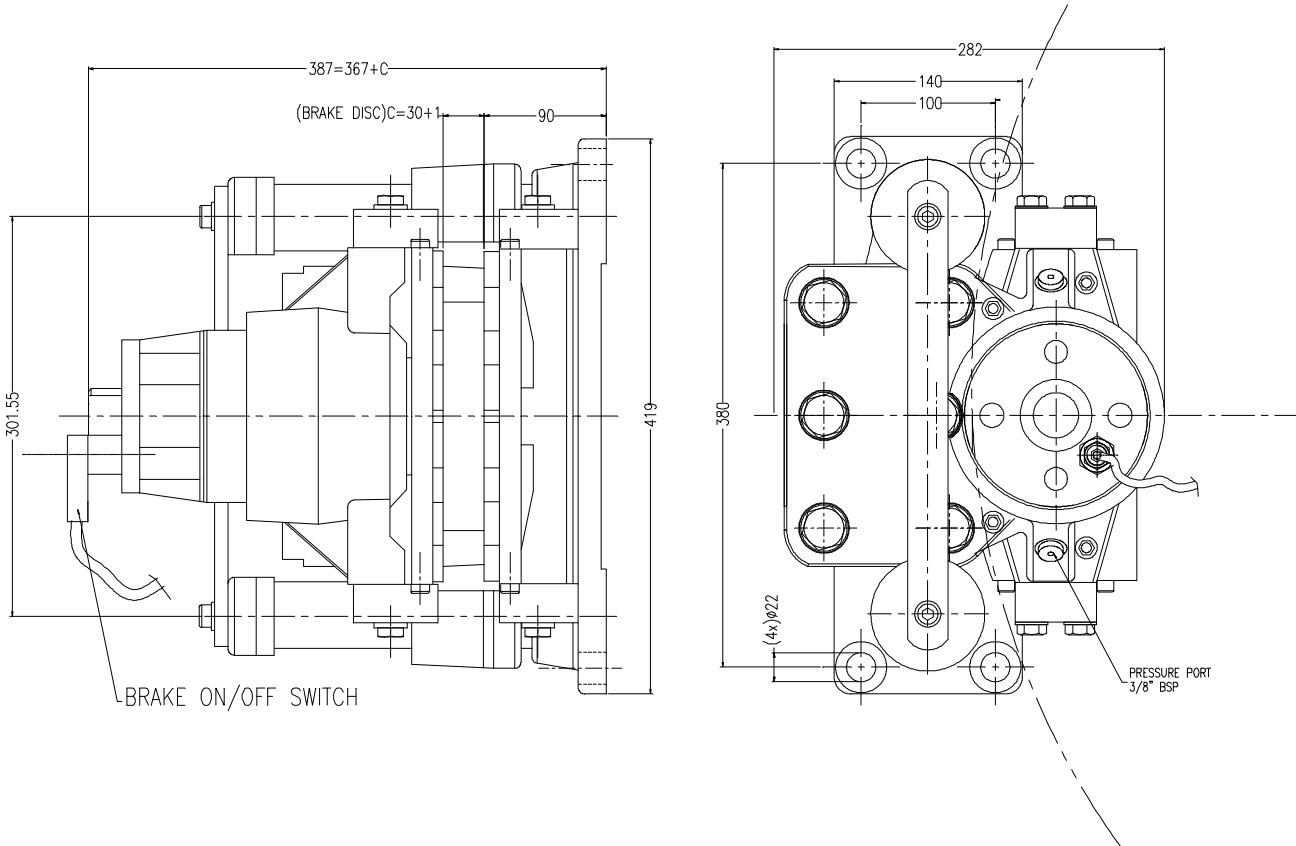

Brake Disc Outer Diameter -mm

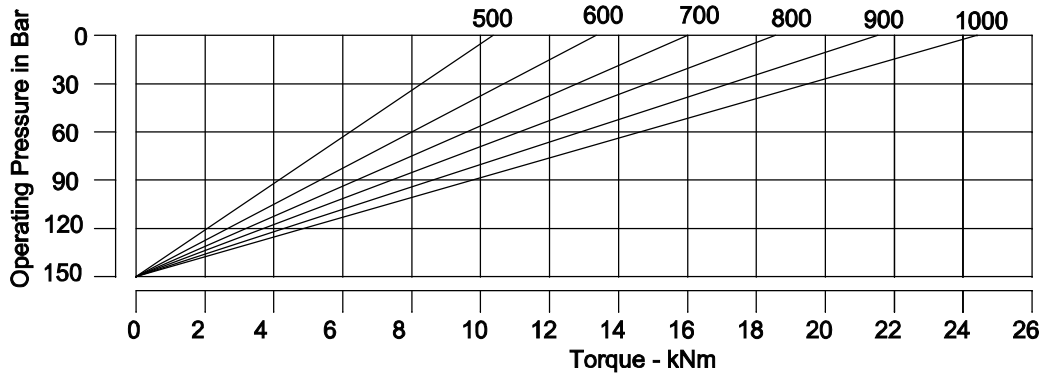

Note: Design & data is subjected to change due to continuous product development

Pad Width - mm	130	Min. Clamping Force (Fc-min.)- N	70000
Pad Area - sq.mm	20000	Max. Clamping Force - N (Fc-max.)	75000
Max. allowable wear of brake pad - mm	5	Min. Braking Force (Fb-min.)- N	56000
Nominal co-efficient of friction - mu	0.4	Max. Braking Force (Fb-max.)- N	60000
Max. Air Gap - mm	1.0	Operating Pressure normal/max. - bar	150 Nor.
Weight - kg.	80	Air / Oil Consumption - cc	180



KATEEL Engineering Industry Private Limited

19/20, R.Bhadrapa Estate, Kamakshipalya, Magadi Main Road,
Bangalore - 560079
INDIA.

Ph: +91-80-3481305, 3484179 Fax: +91-80-3481305, 3218044
email: info@kateel.com, kateel@blr.vsnl.net.in web:www.kateel.com

ISSUE	01
DATE	APR 2011