

Pneumatic Failsafe Disc Brake Caliper

MODEL:

Data Sheet No.

Spring Applied - Air Released

Kf.3M-PF-400

8401.01.016.03.002/R1

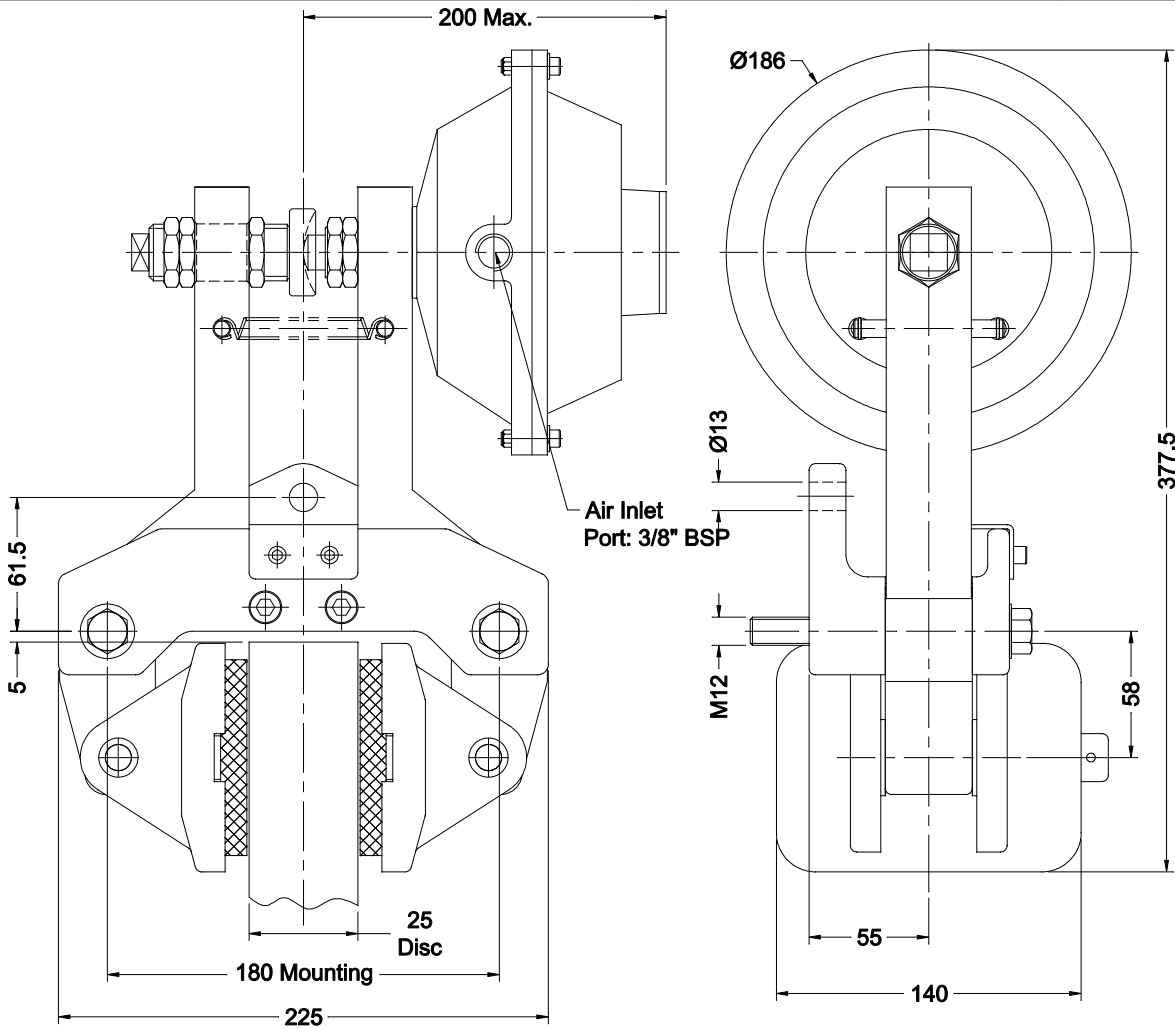

Brake Disc Outer Diameter -mm

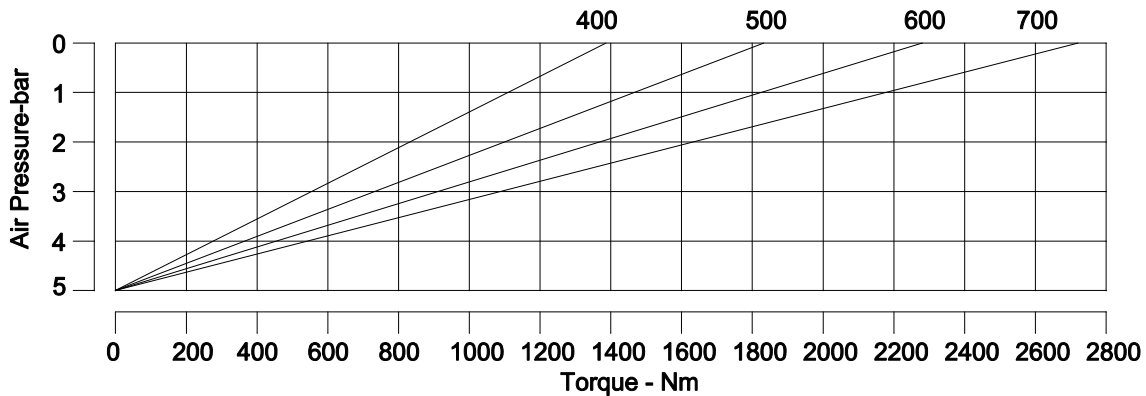

Note: Design & data is subjected to change due to continuous product development

Pad Width - mm	90	Min. Clamping Force (Fc-min.)- N	11180
Pad Area - sq.mm	22500	Max. Clamping Force - N (Fc-max.)	11772
Max. allowable wear of brake pad - mm	5	Min. Braking Force (Fb-min.)- N	8944
Nominal co-efficient of friction - mu	0.4	Max. Braking Force (Fb-max.)- N	9417.6
Max. Air Gap - mm	0.5	Operating Pressure normal/max. - bar	5 Nor./ 7Max.
Weight - kg.	15	Air / Oil Consumption - cc	295



KATEEL Engineering Industry Private Limited

19/20, R.Bhadrapa Estate, Kamakshipalya, Magadi Main Road,

Bangalore - 560079

INDIA.

Ph: +91-80-3481305, 3484179 Fax: +91-80-3481305, 3218044

email: info@kateel.com, kateel@blr.vsnl.net.in web:www.kateel.com

ISSUE	01
DATE	JAN-03